

Adept PA-4 Power Chassis User's Guide

for PA-4 CAT-3

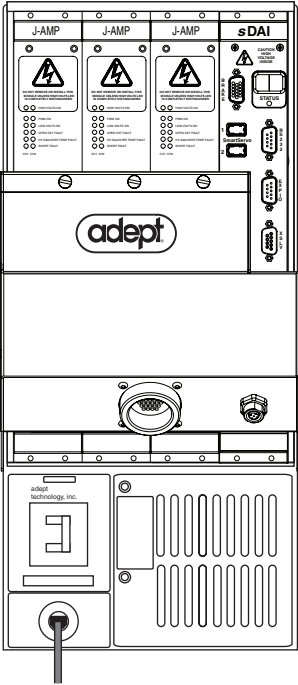

Adept PA-4 Power Chassis User's Guide

for PA-4 CAT-3

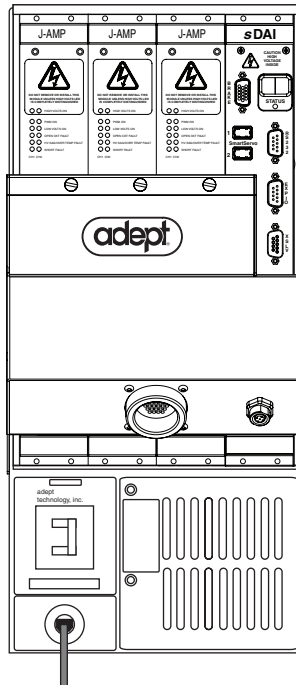

P/N: 02725-000, Rev F
February 2009



5960 Inglewood Drive • Pleasanton, CA 94588 • USA • Phone 925.245.3400 • Fax 925.960.0452

Otto-Hahn-Strasse 23 • 44227 Dortmund • Germany • Phone +49.231.75.89.40 • Fax +49.231.75.89.450

151 Lorong Chuan #04-07 • New Tech Park, Lobby G • Singapore 556741 • Phone +65.6281.5731 • Fax +65.6280.5714

The information contained herein is the property of Adept Technology, Inc., and shall not be reproduced in whole or in part without prior written approval of Adept Technology, Inc. The information herein is subject to change without notice and should not be construed as a commitment by Adept Technology, Inc. This manual is periodically reviewed and revised.

Adept Technology, Inc., assumes no responsibility for any errors or omissions in this document. Critical evaluation of this manual by the user is welcomed. Your comments assist us in preparation of future documentation. Please email your comments to: techpubs@adept.com.

Copyright © 2005-2009 by Adept Technology, Inc. All rights reserved.

Adept, the Adept logo, the Adept Technology logo, AdeptVision, AIM, Blox, Bloxview, FireBlox, Fireview, HexSight, Meta Controls, MetaControls, Metawire, Soft Machines, and Visual Machines are registered trademarks of Adept Technology, Inc.
Brain on Board is a registered trademark of Adept Technology, Inc. in Germany.

ActiveV, Adept 1060 / 1060+, Adept 1850 / 1850 XP, Adept 540 Adept 560, Adept AnyFeeder, Adept Award, Adept C40, Adept C60, Adept CC, Adept Cobra 350, Adept Cobra 350 CR/ESD, Adept Cobra 550, Adept 550 CleanRoom, Adept Cobra 600, Adept Cobra 800, Adept Cobra i600, Adept Cobra i800, Adept Cobra PLC server, Adept Cobra PLC800, Adept Cobra s600, Adept Cobra s800, Adept Cobra s800 Inverted, Adept Cobra s850, Adept Cobra Smart600, Adept Cobra Smart800, Adept DeskTop, Adept FFE, Adept FlexFeeder 250, Adept IC, Adept iSight, Adept Impulse Feeder, Adept LineVision, Adept MB-10 ServoKit, Adept MC, Adept MotionBlox-10, Adept MotionBlox-40L, Adept MotionBlox-40R, Adept MV Adept MV-10, Adept MV-19, Adept MV4, Adept MV-5, Adept MV-8, Adept OC, Adept Python, Adept Quattro s650, Adept Quattro s650H, Adept sDIO, Adept SmartAmp, Adept SmartAxis, Adept SmartController CS, Adept SmartController CX, Adept SmartModule, Adept SmartMotion, Adept SmartServo, Adept sMI6, Adept sSight, Adept Viper s650, Adept Viper s850, Adept Viper s1300, Adept Viper s1700, AdeptCartesian, AdeptCast, AdeptForce, AdeptFTP, AdeptGEM, AdeptModules, AdeptMotion, AdeptMotion Servo, AdeptMotion VME, AdeptNet, AdeptNFS, AdeptOne, AdeptOne-MV, AdeptOne-XL, AdeptRAPID, AdeptSight, AdeptSix, AdeptSix 300, AdeptSix 300 CL, AdeptSix 300 CR, AdeptSix 600, AdeptTCP/IP, AdeptThree, AdeptThree-MV, AdeptThree-XL, AdeptTwo, AdeptVision, AVI AdeptVision, AGS AdeptVision GV, AdeptVision I, AdeptVision II, AdeptVision VME, AdeptVision VXL, AdeptVision XGS, AdeptVision XGS II, AdeptWindows, AdeptWindows Controller, AdeptWindows DDE, AdeptWindows Offline Editor, AdeptWindows PC, AIM Command Server, AIM Dispense, AIM PCB, AIM VisionWare, A-Series, FlexFeedWare, HyperDrive, IO Blox, IO Blox, 88, MicroV+, MotionBlox, MotionWare, ObjectFinder, ObjectFinder 2000, PackOne, PalletWare, sAVI, S-Series, UltraOne, V, V+ and VisionTeach are trademarks of Adept Technology, Inc.

Any trademarks from other companies used in this publication are the property of those respective companies.

Printed in the United States of America

Table of Contents

1	Introduction	9
	1.1 Manual Overview	9
	1.2 Environmental and Facility Requirements	10
	1.3 Compatibility Information	11
	1.4 How Can I Get Help?	13
	Related Manuals	13
	Adept Document Library	14
	1.5 Safety	14
	Dangers, Warnings, Cautions, and Notes	14
	Reading and Training for Users and Operators	15
	Additional Safety Information	16
2	Mounting the PA-4 Chassis	19
	2.1 Space Around the Chassis	19
	2.2 Panel or Rack Mounting	20
	Panel Mounting	20
	Rack Mounting	20
	2.3 Adept PA-4 Dimensions	22
3	Installation for Adept Viper and Cobra s850 Robots	25
	3.1 Overview	25
	3.2 H, I, J, K, and L Amplifier Modules	30
	3.3 sDAI Module	32
	3.4 PA-4 Connectors	34
	Arm Power/Signal Connector	34
	Power and Encoder Connectors	34
	External Brake Connector	34
	3.5 Removing the Interface Box	35
4	Installation for AdeptSix Robots	37
	4.1 Overview	37
	4.2 E, F, and G Amplifier Modules	39
	4.3 sMAI Module	40

- 5 Installation for AdeptOne Robots 43**
 - 5.1 Overview 43
 - 5.2 A Amplifier Modules 44
 - 5.3 B+ Amplifier Module 45
 - 5.4 sEJI Amplifier Module 46

- 6 Maintenance 47**
 - 6.1 Adept PA-4 Air Filter Inspection and Cleaning 47
 - 6.2 PA-4 Power Chassis Circuit Breaker and Fuse Information 48
 - Chassis Circuit Breaker 48
 - Chassis and Amplifier Module Fuses 48
 - 6.3 Removing and Installing Amplifier and Control Modules 48
 - Removing Amplifier Modules 49
 - Installing Amplifier Modules 49
 - 6.4 PA-4 CAT-3 Power Chassis LED Functions 50
 - 6.5 Changing the Power Chassis Voltage Setting 51
 - Changing From 380-415 VAC to 200-240 VAC 51
 - Part 1 – Insulating the Power Chassis Power Cord 51
 - Part 2 – Rotating the Voltage Selector in the Power Chassis 52
 - Changing From 200-240 VAC to 380-415 VAC 53
 - Part 1 – Rotating the Voltage Selector in the Power Chassis 53
 - Part 2 – Insulating the Power Chassis Power Cord 53

- Index 55**

List of Figures

Figure 1-1.	Adept PA-4 Power Chassis	9
Figure 1-2.	Product ID Label for CAT-3 PA-4	11
Figure 2-1.	Installing Mounting Brackets on an Adept PA-4 Chassis	21
Figure 2-2.	Adept PA-4 Power Chassis Dimensions for Adept Viper and Cobra s850 Robots	22
Figure 2-3.	Basic Adept PA-4 Power Chassis Dimensions (Without Modules)	23
Figure 2-4.	PA-4 Dimensions With Mounting Brackets Installed	24
Figure 3-1.	Adept PA-4 Power Chassis with sDAI Module (Viper s650/s850 Robots)	26
Figure 3-2.	Adept PA-4 Power Chassis with sDAI Module (Cobra s850 Robots)	27
Figure 3-3.	Adept PA-4 Power Chassis with sDAI 100W Module (Viper s1300 Robots)	28
Figure 3-4.	Adept PA-4 Power Chassis with sDAI HP Module (Viper s1700 Robots)	29
Figure 3-5.	J Amplifier Module Connectors and Indicators	31
Figure 3-6.	sDAI Module Connectors and Indicators	32
Figure 3-7.	External Brake Connector Pinouts	34
Figure 3-8.	PA-4 with Interface Box Tilted Open	35
Figure 4-1.	Adept PA-4 Power Chassis with sMAI Module	38
Figure 4-2.	Amplifier Module Connectors and Indicators	39
Figure 4-3.	sMAI Module Connectors and Indicators	40
Figure 5-1.	PA-4 with sEJI Module	43
Figure 5-2.	A Amplifier Connectors and Indicators	44
Figure 5-3.	B+ Amplifier Connectors and Indicators	45
Figure 5-4.	sEJI Module Connectors and Indicators	46
Figure 6-1.	PA-4 Chassis LED Locations	50
Figure 6-2.	Insulating Blue Wire in Power Cord (200-240 VAC)	52
Figure 6-3.	Changing Voltage in Power Chassis	52
Figure 6-4.	Removing Insulation from Blue Wire in Power Cord (380-415 VAC)	54

1.1 Manual Overview

This manual describes the installation and maintenance of the Adept PA-4 CAT-3 power chassis as it is used in the:

- Adept Viper and Cobra s850 robot product lines (see [Chapter 3](#))
- AdeptSix robot product line (see [Chapter 4](#))
- AdeptOne robot with the Adept SmartController product line (see [Chapter 5](#))

NOTE: For this manual, occurrences of Viper s650/s850 refer to those robots used with the PA-4 power chassis.

The following chapters apply to all four families of robots:

- [Chapter 1 - Introduction](#)
- [Chapter 2 - Mounting the PA-4 Chassis](#)
- [Chapter 6 - Maintenance](#)

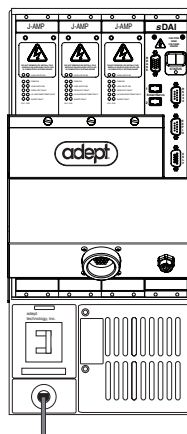

Figure 1-1. Adept PA-4 Power Chassis

NOTE: This PA-4 CAT-3 is also compatible with earlier Adept products. See [Section 1.3 on page 11](#).

1.2 Environmental and Facility Requirements

The Adept PA-4 installation must meet the operating environment requirements shown in **Table 1-1**. See the robot manual that came with your system for environment requirements for the robot.

Table 1-1. Adept PA-4 Operating Environment Requirements

Ambient temperature	5° to 40°C (41° to 104°F)
Humidity	5 to 90%, noncondensing
Altitude	up to 2000 m (6500 ft)
Pollution degree	2 (IEC 1131-2/EN 61131-2)
Free space around power chassis for proper cooling	50 mm (2 inches) in front 25 mm (1 inch) at top
Power chassis subassembly protection class, unmounted	IP-20 (NEMA Type 1)
Recommendations for customer-supplied enclosure for Adept power chassis (mandatory for installations in EU or EEA countries).	Enclosure should meet EN 60204 (IEC 204) requirements and be rated at IP-54. Also, enclosure must provide a method of locking the enclosure power-disconnect in the OFF position.

1.3 Compatibility Information

The CAT-3 version of the PA-4, P/N 01044-000, was developed primarily to support the Category 3 robot systems. You can identify this new version of the PA-4 from earlier versions in two ways:

- the product ID label with the new part number 01044-000, located on the right side of the chassis. See [Figure 1-2](#).
- on the lower-right side of the PA-4 front panel, there are additional labels for diagnostic LEDs. See [Figure 6-1 on page 50](#).

This new PA-4 is also backwards-compatible with earlier Adept systems, such as Adept Cobra and Adept XL robots. See [Table 1-2 on page 12](#).

NOTE: The CAT-3 version of the PA-4 in AdeptSix robot systems must use the sMAI (smart Multi-Axis Interface) or MAI-2 module; it is not compatible with the earlier MAI-1 module.



Figure 1-2. Product ID Label for CAT-3 PA-4

Table 1-2. PA-4 Plug-in Module Compatibility

Modules Compatible with CAT-3 PA-4	
Robot Control Modules	
sDAI	Adept Viper s650/s850 and Cobra s850 robot systems
sDAI-100W	Adept Viper s1300 robot systems
sDAI-HP	Adept Viper s1700 robot systems
sMAI	AdeptSix robot systems, starting in October 2004
MAI-2	AdeptSix robot systems prior to the sMAI module
sEJI	AdeptOne robot systems
Amplifier Modules	
<p>NOTE: “A” amplifiers are single-channel, plug-in modules that contain the circuitry and amplifying components to drive one motor. All amplifiers labeled “B+” and later are “dual” (dual-channel) plug-in modules that contain the circuitry and amplifying components for driving two motors.</p>	
H and I Amps	Adept Viper s1700 robot systems
J Amp	Adept Viper s650/s850 and Adept Viper s1300 robot systems
K Amp	Adept Viper s1300 robot systems
L Amp	Adept Cobra s850 robot systems
E Amp	AdeptSix 300 and 300CR robot systems
F and G Amps	AdeptSix 600 robot systems
A and B+ Amps	AdeptOne with SmartController, AdeptOne-XL, and AdeptThree-XL robot systems
B+II Amp	AdeptVicron 300S robot systems
C Amp	Adept Cobra 600 and 800 robot systems
MV-4 Insert	Used when PA-4 is configured as a Compact Controller
Modules NOT Compatible with CAT-3 PA-4	
MAI-1 (just MAI on label)	The original MAI module was used in early AdeptSix 300 robot systems. This module can only be used in the earlier PA-4, P/N 30336-31000.

1.4 How Can I Get Help?

Refer to the *How to Get Help Resource Guide* (Adept P/N 00961-00700) for details on getting assistance with your Adept software and hardware.

Additionally, you can access information sources on Adept's corporate Web site:

<http://www.adept.com>

Related Manuals

This manual covers the installation, operation, and maintenance of an Adept PA-4 power chassis. There are additional manuals that cover programming the system, reconfiguring installed components, and adding other optional components; see **Table 1-3**. These manuals are available on the Adept Document Library CD-ROM shipped with each system.

Table 1-3. Related Manuals

Manual Title	Description
<i>AdeptViper s650/s850 Robot User's Guide</i> <i>AdeptViper s1300 Robot User's Guide</i> <i>AdeptViper s1700 Robot User's Guide</i>	Contains complete information on the installation and operation of the Adept Viper s650/s850, Adept Viper s1300, and Adept Viper s1700 robots.
<i>Adept Cobra s850 Robot User's Guide</i> <i>Adept Cobra s850 Inverted Robot User's Guide</i>	Contains complete information on the installation and operation of the Adept Cobra s850 robots.
<i>AdeptOne with SmartController User's Guide</i>	Contains complete information on the installation and operation of the AdeptOne with SmartController robot.
<i>AdeptSix 300 Robot Instruction Handbook</i> <i>AdeptSix 300CR Robot Instruction Handbook</i> <i>AdeptSix 600 Robot Instruction Handbook</i>	Contains complete information on the installation and operation of the AdeptSix 300, AdeptSix 300CR, and AdeptSix 600 robots.
<i>Adept SmartController User's Guide</i>	Contains complete information on the installation and operation of the Adept SmartController.
<i>AdeptWindows Installation Guide</i>	Describes complex network installation, installation and use of NFS server software, the AdeptWindows Offline Editor, and the AdeptWindows DDE software.

Adept Document Library

The Adept Document Library (ADL) contains documentation for Adept products. You can access the ADL from:

- the Adept Software CD shipped with your system
- the separate ADL CD shipped with your system.
- the Adept Web site. Select Document Library from the Adept home page. To go directly to the Adept Document Library, type the following URL into your browser:

http://www.adept.com/Main/KE/DATA/adept_search.htm

To locate information on a specific topic, use the Document Library search engine on the ADL main page. To view a list of available product documentation, select the Document Titles option.

1.5 Safety

The Adept PA-4 operates on either 200-240 VAC or 380-415 VAC. You must be very careful when installing and operating these products. Read and understand the Safety chapter in your robot manual before attempting to install these products. Observe all warnings in this manual and in the robot and controller manuals as you set up your Adept system.

Dangers, Warnings, Cautions, and Notes

There are six levels of special alert notation used in this manual. In descending order of importance, they are:



DANGER: This indicates an imminently hazardous electrical situation which, if not avoided, will result in death or serious injury.



DANGER: This indicates an imminently hazardous situation which, if not avoided, will result in death or serious injury.



WARNING: This indicates a potentially hazardous electrical situation which, if not avoided, could result in injury or major damage to the equipment.



WARNING: This indicates a potentially hazardous situation which, if not avoided, could result in injury or major damage to the equipment.



CAUTION: This indicates a situation which, if not avoided, could result in damage to the equipment.

NOTE: This provides supplementary information, emphasizes a point or procedure, or gives a tip for easier operation.

Reading and Training for Users and Operators

Adept systems can include computer-controlled mechanisms that are capable of moving at high speeds and exerting considerable force. Like all robot and motion systems, and most industrial equipment, they must be treated with respect by the user and the operator.

This manual should be read by all personnel who operate or maintain Adept systems, or who work within or near the workcell.

The installation and use of Adept products must comply with all safety instructions and warnings in this manual. Installation and use must also comply with all applicable local and national requirements and safety standards.

We recommend you read the *American National Standard for Industrial Robot Systems - Safety Requirements*, published by the Robotic Industries Association (RIA) in conjunction with the American National Standards Institute. The publication, ANSI/RIA R15.06, contains guidelines for robot system installation, safeguarding, maintenance, testing, startup, and operator training.

We also recommend you read the International Standard IEC 204 or the European Standard EN 60204, *Safety of Machinery – Electrical Equipment of Machines*, and ISO 10218 (EN 775), *Manipulating Industrial Robots – Safety*, particularly if the country of use requires a CE-certified installation.

This manual assumes that the user has attended an Adept training course and has a basic working knowledge of the system. The user should provide the necessary additional training for all personnel who will be working with the system.

Additional Safety Information

The standards and regulations listed in this manual contain additional guidelines for robot system installation, safeguarding, maintenance, testing, start-up, and operator training. **Table 1-4** lists some sources for the various standards.

Table 1-4. Sources for International Standards and Directives

<p>SEMI International Standards 3081 Zanker Road San Jose, CA 95134 USA</p> <p>Phone: 1.408.943.6900 Fax: 1.408.428.9600 http://www.semi.org/</p>	<p>American National Standards Institute (ANSI) 11 West 42nd Street, 13th Floor New York, NY 10036 USA</p> <p>Phone 212-642-4900 Fax 212-398-0023 http://www.ansi.org</p>
<p>BSI Group (British Standards) 389 Chiswick High Road London W4 4AL United Kingdom</p> <p>Phone +44 (0)20 8996 9000 Fax +44 (0)20 8996 7400 http://www.bsi-global.com</p>	<p>Document Center, Inc. 1504 Industrial Way, Unit 9 Belmont, CA 94002 USA</p> <p>Phone 415-591-7600 Fax 415-591-7617 http://www.document-center.com</p>
<p>DIN, Deutsches Institut für Normung e.V. German Institute for Standardization Burggrafenstrasse 6 10787 Berlin Germany</p> <p>Phone.: +49 30 2601-0 Fax: +49 30 2601-1231 http://www.din.de http://www2.beuth.de/ (publishing)</p>	<p>Global Engineering Documents 15 Inverness Way East Englewood, CO 80112 USA</p> <p>Phone 800-854-7179 Fax 303-397-2740 http://global.ihs.com</p>
<p>IEC, International Electrotechnical Commission Rue de Varembe 3 PO Box 131 CH-1211 Geneva 20 Switzerland</p> <p>Phone 41 22 919-0211 Fax 41 22 919-0300 http://www.iec.ch</p>	<p>Robotic Industries Association (RIA) 900 Victors Way PO Box 3724 Ann Arbor, MI 48106 USA</p> <p>Phone 313-994-6088 Fax 313-994-3338 http://www.robotics.org</p>

Table 1-4. Sources for International Standards and Directives (Continued)

<p>Underwriters Laboratories Inc. 333 Pfingsten Road Northbrook, IL 60062-2096 USA</p> <p>Phone: +1-847-272-8800 Fax: +1-847-272-8129 http://www.ul.com/</p>	
---	--

Mounting the PA-4 Chassis

2

The PA-4 chassis must be installed in a suitable enclosure that provides the environment (temperature, etc.) specified in [Table 1-1 on page 10](#). The enclosure must also provide a power disconnect with a method for user service personnel to lock the power in the OFF position. This is required for safety, including national and international standards, such as:

- OSHA 'Lockout/Tagout' (USA)
- IEC 204-1
- EN 60204-1



DANGER: Failure to provide and use a suitable disconnect device could cause death or injury to personnel.

2.1 Space Around the Chassis

When the PA-4 chassis is installed, you must allow 50 mm (2 in) at the front of the chassis and 25 mm (1 in.) at the top of the chassis for proper air cooling.



CAUTION: It is important to keep the air filters clean so the forced air cooling system can work efficiently. See [Section 6.1 on page 47](#) for details on cleaning the filters.

2.2 Panel or Rack Mounting

The PA-4 chassis can be panel or rack mounted using the optional mounting brackets (P/N 90336-31030F). The brackets can be attached at the rear of the PA-4 chassis for panel mounting, or they can be attached to the front of the PA-4 chassis for rack mounting.



WARNING: Do not use screws other than those supplied. There is a printed circuit board located at the bottom of the chassis. Using screws longer than those supplied could cause an electrical short, damage electrical components, or pinch wires.

Panel Mounting

To panel-mount the PA-4 chassis, install one bracket on each side near the back of the chassis. Use the screws and washers from the accessories kit (see [Figure 2-1 on page 21](#)).

Rack Mounting

Use the mounting brackets, screws, and washers to rack-mount the PA-4 chassis in a standard 19-inch equipment rack. You must build an extender panel and attach it to the mounting brackets. The brackets can be installed in two positions for rack mounting: “flush” and “set-back” (see [Figure 2-1 on page 21](#)).

NOTE: The rack-mount “flush” option is not available for PA-4 power chassis shipped with Adept Viper and Cobra s850 systems. These systems must use the “set-back” or “panel-mount” options.

To Install Mounting Brackets on Adept PA-4 Power Chassis:

- Remove (and discard) 3 existing countersunk screws from side of chassis at locations shown in drawing.
- Place bracket in desired position and secure with M4 pan-head screws and washers from accessories kit where indicated in drawing.
- Repeat process for other side of chassis.

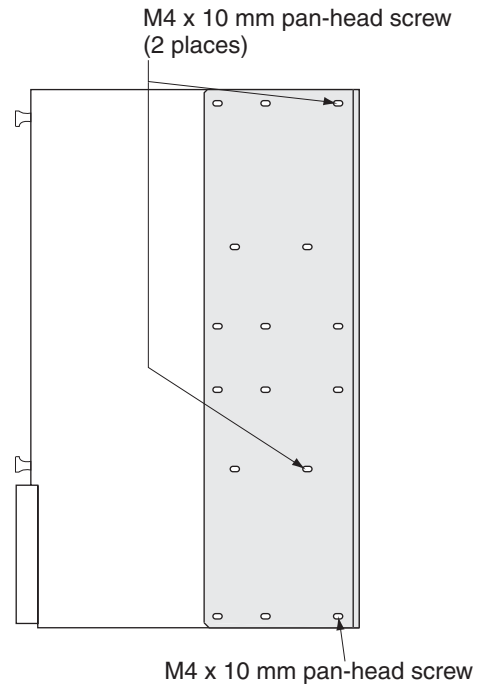

Panel Mount

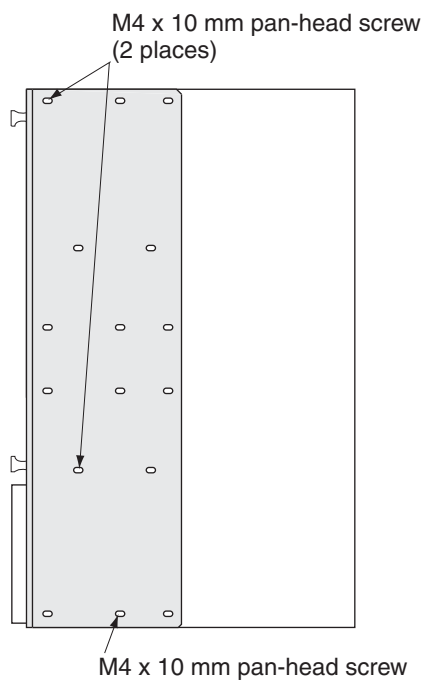

Rack Mount – Flush

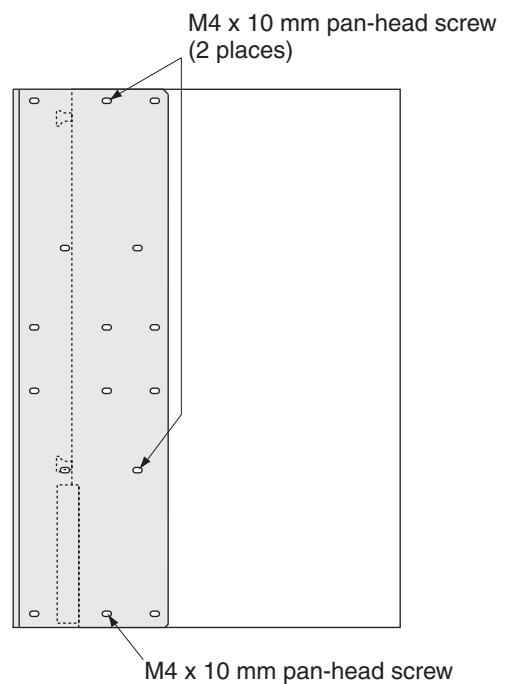

Rack Mount – Set-Back

Figure 2-1. Installing Mounting Brackets on an Adept PA-4 Chassis

NOTE: See [Section 2.3 on page 22](#) for PA-4 dimensions.



WARNING: Do not turn on AC power to the PA-4 until you have completed installation of the robot, controller, and any additional equipment. Refer to your robot manual to verify system installation and activate system power.

Refer to your robot manual for information on PA-4 chassis power requirements and instructions on connecting AC power to the PA-4 chassis.

2.3 Adept PA-4 Dimensions

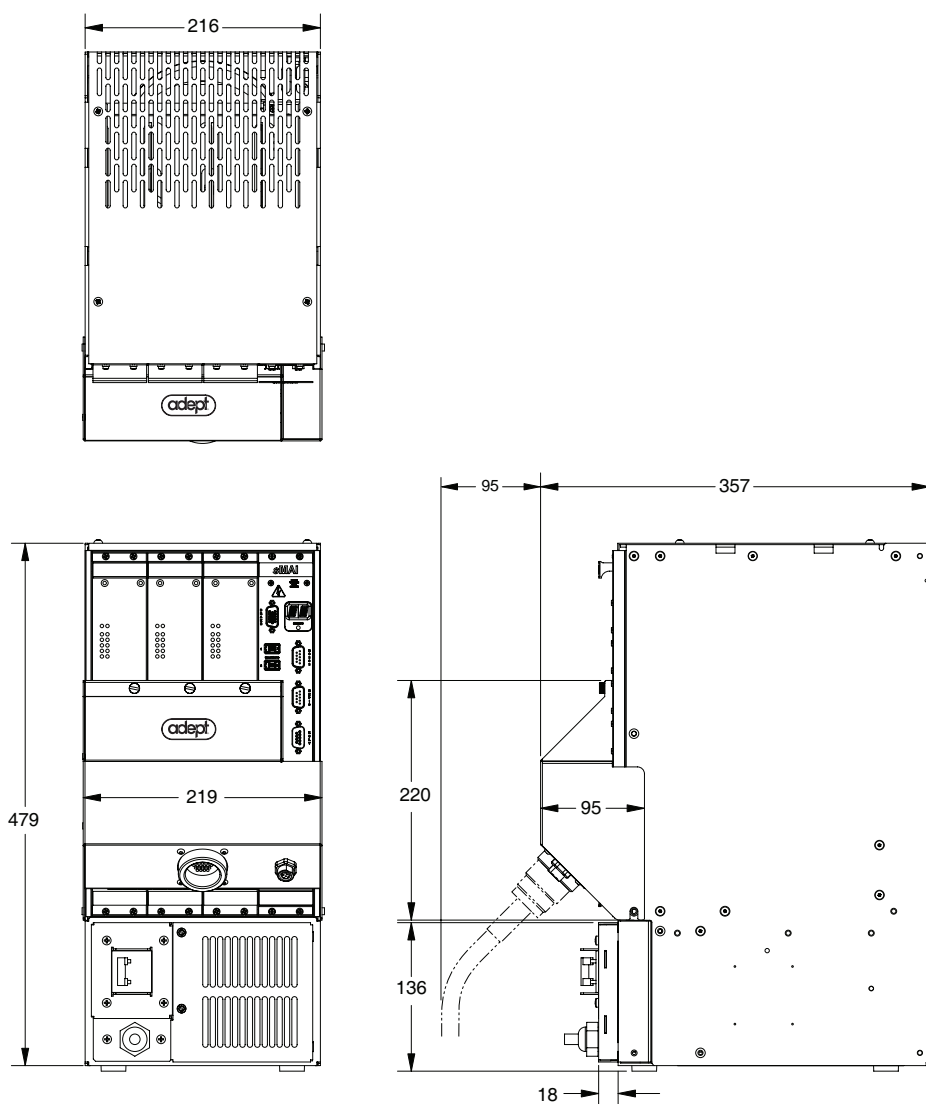

Figure 2-2. Adept PA-4 Power Chassis Dimensions for Adept Viper and Cobra s850 Robots

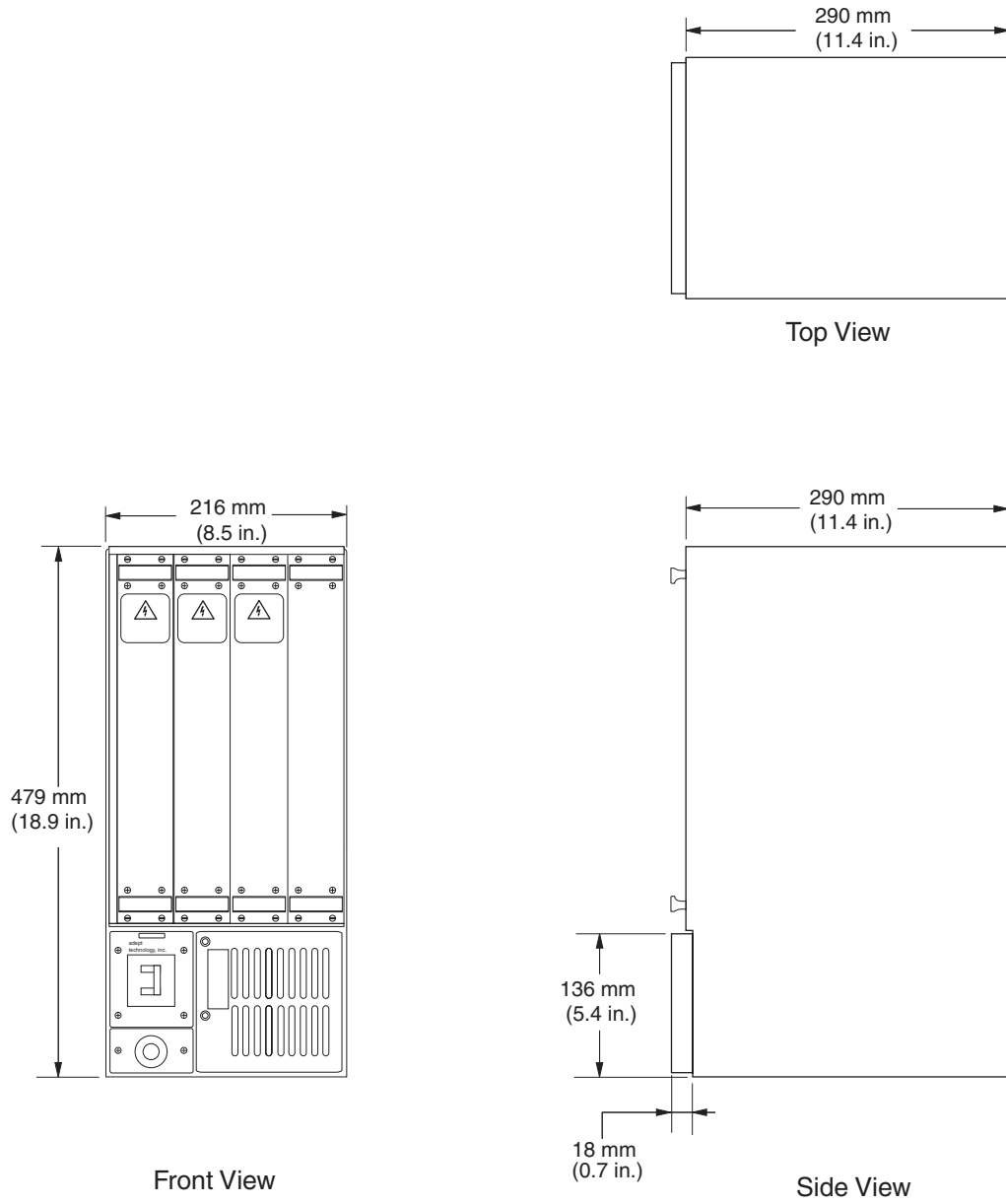
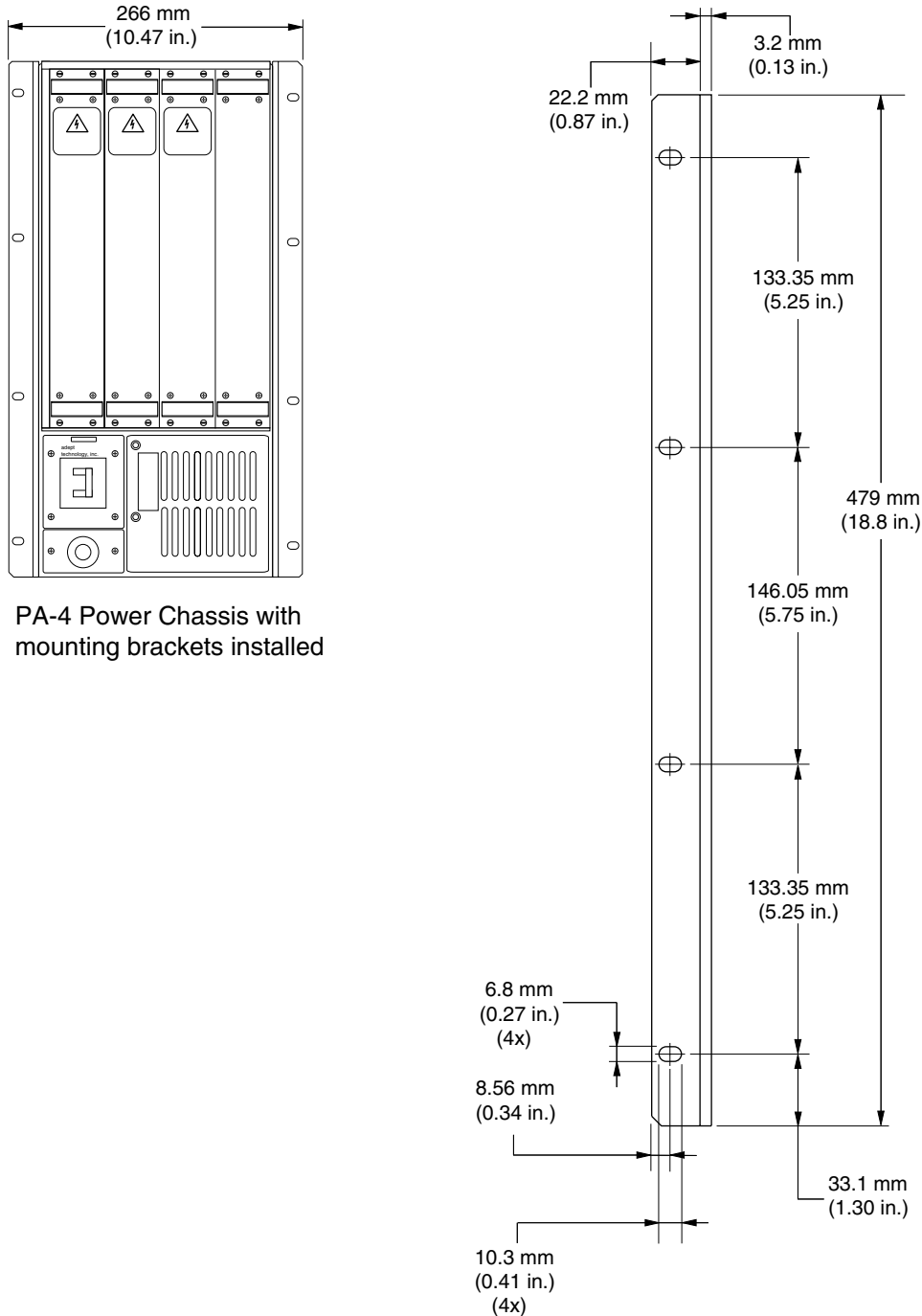

Figure 2-3. Basic Adept PA-4 Power Chassis Dimensions (Without Modules)



PA-4 Power Chassis with mounting brackets installed

Figure 2-4. PA-4 Dimensions With Mounting Brackets Installed

Installation for Adept Viper and Cobra s850 Robots

3

3.1 Overview

The PA-4 CAT-3 includes AC-DC power conversion electronics that support a range of Adept power amplifiers and robot control modules. In addition, the PA-4 CAT-3 includes dual (redundant) high-power AC contactors that, in combination with the sDAI, meet the Category-3 E-Stop requirements per EN-954. The PA-4 is configured with the following amplifier modules to support the Adept Viper robot systems listed below.

- Viper s1700: H and I amps
- Viper s1300: J and K amps
- Viper s650/s850: J amps
- Cobra s850: L amps

The amplifiers in the Adept Viper robot system are controlled by an sDAI distributed-control module. The sDAI module resides in the PA-4 chassis and contains a RISC microprocessor and interface circuitry that close the servo loops for high-performance robot motion. The sDAI is connected to a host Adept SmartController via the SmartServo interface (based on IEEE 1394, also called “FireWire®”).

NOTE: The Adept Viper s650/s850 and Cobra s850 robots use the standard sDAI. The Adept Viper s1300 robot uses the 100W version of the sDAI. The Adept Viper s1700 robot uses the HP version of the sDAI.

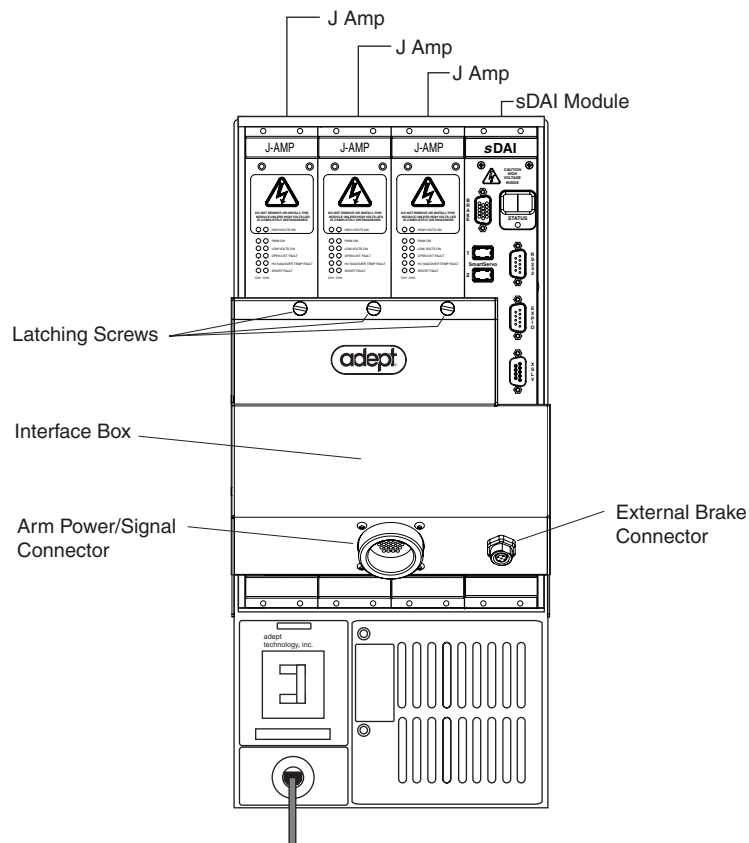

Figure 3-1. Adept PA-4 Power Chassis with sDAI Module (Viper s650/s850 Robots)

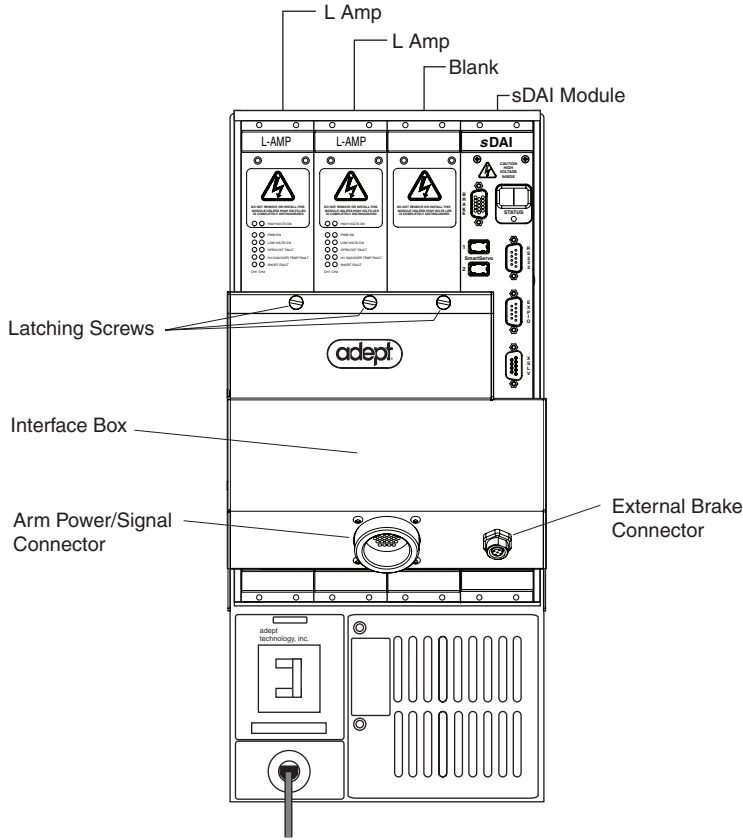

Figure 3-2. Adept PA-4 Power Chassis with sDAI Module (Cobra s850 Robots)

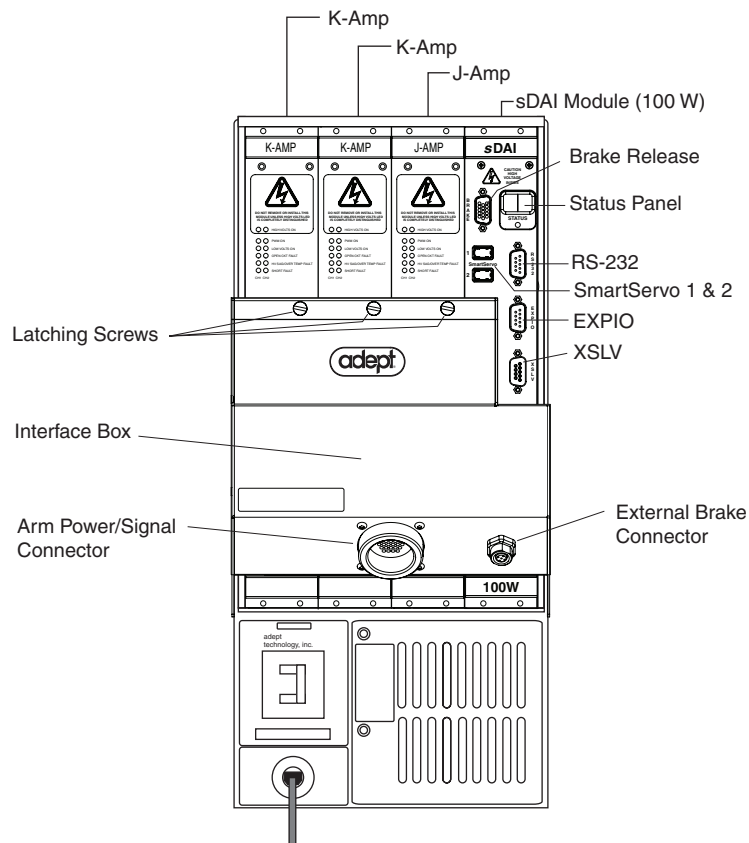

Figure 3-3. Adept PA-4 Power Chassis with sDAI 100W Module (Viper s1300 Robots)

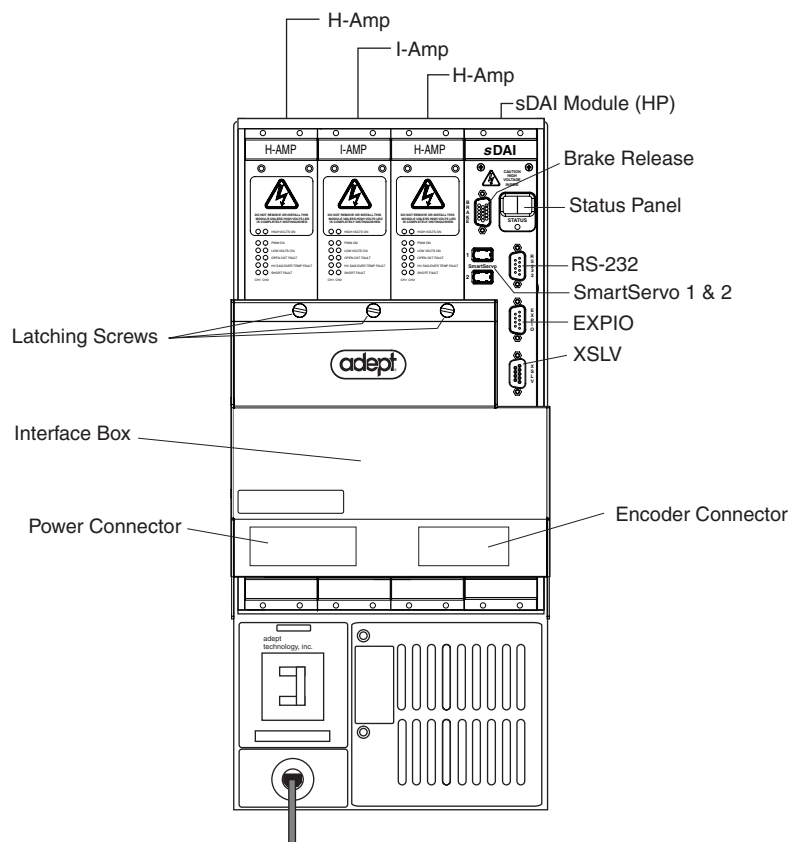

Figure 3-4. Adept PA-4 Power Chassis with sDAI HP Module (Viper s1700 Robots)

The PA-4 CAT-3 features:

- AC-DC power conversion for amplifier modules
- Multiple amplifier/module support (4 slots)
- EN-954 Category 3 compliant E-Stop contactors

The sDAI module features:

- RISC microprocessor for servo loop control
- Interfaces to 4 or 6 axes of Adept power amplifiers
- Interfaces to robust digital serial absolute encoders
- Interfaces to 4 or 6 axes of electromechanical brakes
- Redundant E-Stop safety circuits.
- SmartServo (IEEE-1394) interface for distributed control

See [Section 3.3 on page 32](#) for a description of the connectors and indicators on the sDAI.

3.2 H, I, J, K, and L Amplifier Modules

The H and I Amplifier modules are “dual” (dual-channel) plug-in modules that contain the circuitry and amplifying components for driving two of the motors in an Adept Viper s1700 robot. See [Table 3-1](#).

The J Amplifier modules are “dual” (dual-channel) plug-in modules that contain the circuitry and amplifying components for driving two of the motors in an Adept Viper s650/s850 robot or two of the motors in an Adept Viper s1300 robot. See [Table 3-1](#).

The K Amplifier modules are “dual” (dual-channel) plug-in modules that contain the circuitry and amplifying components for driving two of the motors in an Adept Viper s1300 robot. See [Table 3-1](#).

The L Amplifier modules are “dual” (dual-channel) plug-in modules that contain the circuitry and amplifying components for driving two of the motors in an Adept Cobra s850 robot. See [Table 3-1](#).

Table 3-1. Amplifier Functions

	Amp Slot 1 (left)	Amp Slot 2 (center)	Amp Slot 3 (right)
Adept Viper s650/s850 Robot	J Amp #1 drives motors 1 and 4	J Amp #2 drives motors 2 and 5	J Amp #3 drives motors 3 and 6
Adept Viper s1300 Robot	K Amp #1 drives motors 1 and 4	K Amp #2 drives motors 2 and 5	J Amp drives motors 3 and 6
Adept Viper s1700 Robot	H Amp #1 drives motors 1 and 4	I Amp drives motors 2 and 5	H Amp #2 drives motors 3 and 6
Adept Cobra s850 Robot	L Amp #1 drives motors 1 and 4	L Amp drives motors 2 and 3 NOTE: Motor 3 uses the connector designated for Motor 5.	Blank Plate Not used (blank cover plate installed)

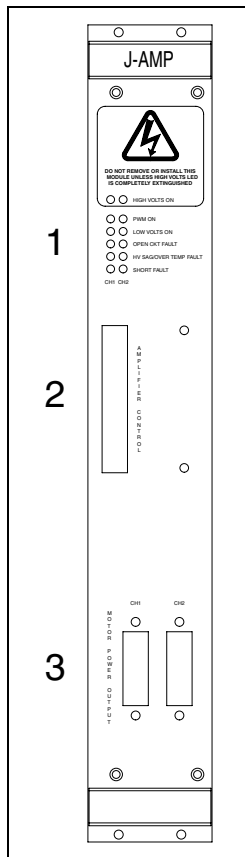

1. **Status LEDs.** The left column of LEDs is for the first motor controlled by this module; the right column is for the second motor controlled by this module. When an LED is turned on, it indicates the following conditions:

High Volts On indicates high voltage to the amps is turned on.

PWM On indicates that current servo is on. It does not go on until calibration is complete.

Low Volts On indicates the low voltage supply in the power chassis is on.

Note: the three LED pairs below indicate faults and are visible momentarily before the system turns off.

Open Ckt Fault indicates that an open circuit in the motor leads has been detected.

HV Sag/Over Temp Fault left LED, when lit, indicates that the fault was caused by a sag in voltage. The right LED, when lit, indicates the fault was caused by an over-temperature condition on the amplifier heat sink.

Short Fault indicates that an over-current in the motor leads has been detected.

2. **Amplifier Control** connector: the sDAI-to-Amp cable is installed on this connector at the factory. This connector is covered by the Interface Box.
3. **Motor Power Outlet** connectors: the Joint 1 to 6 power cables from the Interface Box wiring harness are installed on these connectors.

Figure 3-5. J Amplifier Module Connectors and Indicators

NOTE: The above descriptions apply to the H, I, J, K, and L amplifier modules.

3.3 sDAI Module

The Adept sDAI module is a single-slot board designed to control the motion axes on an Adept Viper robot. The sDAI connectors and indicators are described in [Figure 3-6](#).

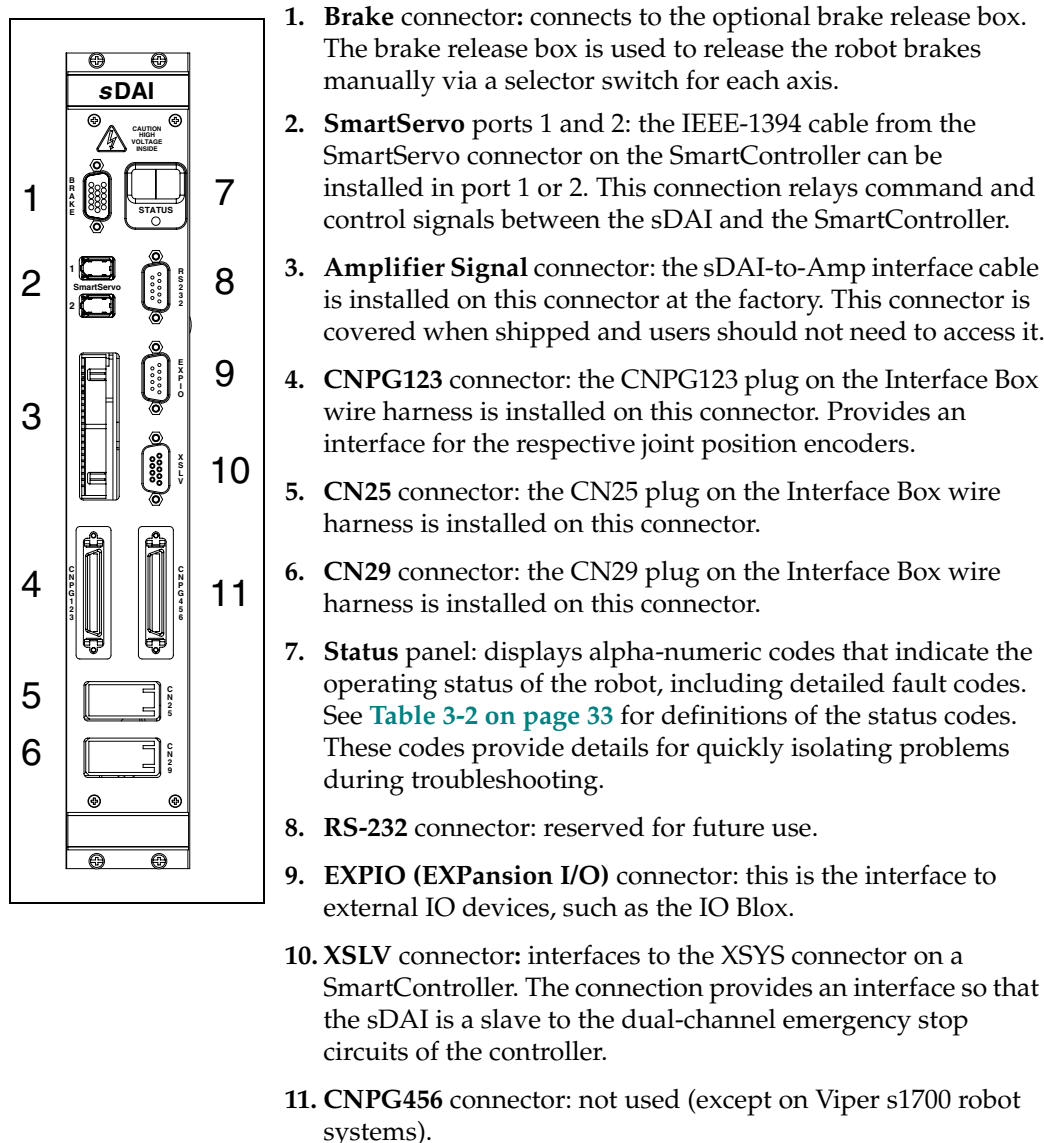

Figure 3-6. sDAI Module Connectors and Indicators

NOTE: The above descriptions apply to the sDAI (used with the Adept Viper s650/s850 and Cobra s850 robots), the sDAI 100W (used with the Adept Viper s1300 robot,) and the sDAI HP (used with the Viper s1700 robot).

Table 3-2. sDAI Status Panel Codes

LED	Status Code	LED	Status Code
OK	No Fault	h#	High Temp Amp (Joint #)
ON	High Power ON Status	H#	High Temp Encoder (Joint #)
MA	Manual Mode	hV	High Voltage Bus Fault
24	24 V Supply Fault	I#	Initialization Stage (Step #)
A#	Amp Fault (Joint #)	M#	Motor Stalled (Joint #)
B#	IO Blox Fault (Address #)	NV	Non-Volatile Memory
AC	AC Power Fault	P#	Power System Fault (Code #)
D#	Duty Cycle Exceeded (Joint #)	PR	Processor Overloaded
E#	Encoder Fault (Joint #)	RC	RSC Fault
ES	E-Stop	SW	Watchdog Timeout
F#	External Sensor Stop	S#	Safety System Fault (Code #)
FM	Firmware Mismatch	T#	Safety System Fault (Code 10 + #)
FW	IEEE-1394 Fault	V#	Hard Envelope Error (Joint #)

For more information on status codes, go to the Adept Document Library on the Adept Web site, and in the Procedures, FAQs, and Troubleshooting section, look for the *Adept Status Code Summary* document.

3.4 PA-4 Connectors

The connectors on the PA-4 EMC box are described below.

Arm Power/Signal Connector

The circular Arm Power/Signal connector on the PA-4 shipped with Viper s650/s850, Viper s1300, and Cobra s850 systems carries all the motor power and encoder feedback connections between the controller and the robot. See [Figure 3-1 on page 26](#) and [Figure 3-3 on page 28](#).

Power and Encoder Connectors

The two rectangular connections on the Viper s1700 serve the same purpose as the Arm Power/Signal connector on the PA-4 shipped with Viper s650/s850 and Viper s1300 systems. See [Figure 3-4 on page 29](#). However, the Viper s1700 uses two cables. The Power connector carries motor power connections and the Encoder connector carries encoder feedback connections.

External Brake Connector

The External Brake connector's wire list and pinouts are shown below. See [Figure 3-1 on page 26](#) for the connector's location.

This connector provides a low-side driver output that is suitable for driving a 24 V device, such as a solenoid or pneumatic valve. This driver is internally activated in response to a J1 brake release command. The solenoid or valve should be connected between pin 1 (24 V source) and pin 2 (switched GND return). This output is capable of driving up to 10 W (400 mA @ 24 V). Pins 3 and 4 are reserved for future functionality.

Table 3-3. External Brake Connector Wire List

Pin #	Wire Color	Signal
Circ 2 - pin 1	brown	+24 VDC
Circ 2 - pin 2	white	EXT Brake
Circ 2 - pin 3	blue	+24 VDC
Circ 2 - pin 4	black	EXT Lamp

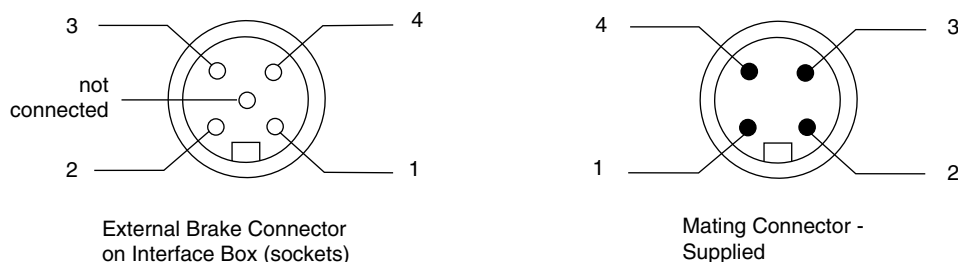

Figure 3-7. External Brake Connector Pinouts

The mating connector is supplied in the accessory kit. Adept part number:

05180-000, PLUG, MALE, 4P, MICRO (M12), M12X1 THREAD

Third party vendors for the mating connector:

- Lumberg, part #: RSC 4/9
- Mencom, part #: MDC-4MP-FWX

NOTE: The PA-4 in Viper s1700 systems does not have an External Brake connector.

3.5 Removing the Interface Box

1. Turn off the PA-4 power chassis and the SmartController.
2. Loosen the 3 latching screws at the top of the Interface Box. See [Figure 3-1 on page 26](#).
3. Lift the Interface Box up slightly, and tilt it down. Be careful to avoid loosening the copper-colored finger strip shielding. See [Figure 3-8](#).

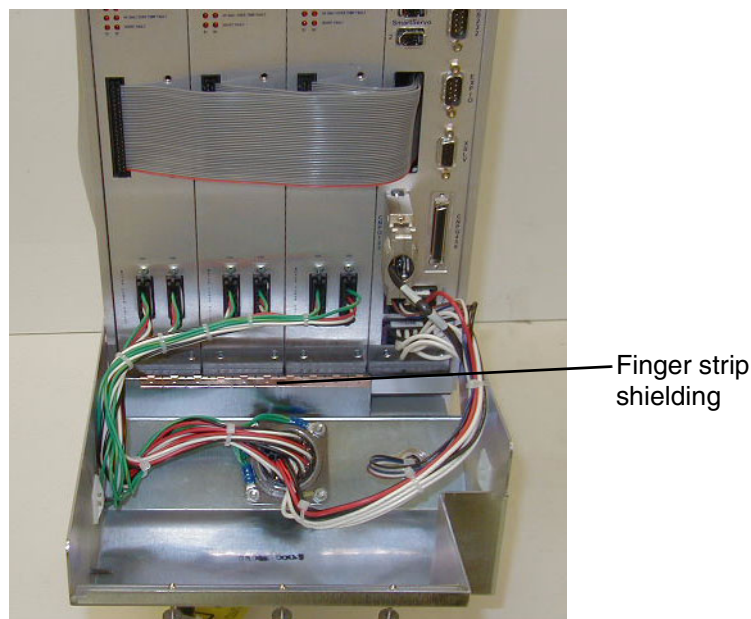

Figure 3-8. PA-4 with Interface Box Tilted Open

4. Disconnect all of the cables from the Interface Box wire harness to the PA-4 modules.
5. Remove the Interface Box and set it aside, so you have full access to the PA-4 modules.

Installation for AdeptSix Robots

4

4.1 Overview

The Adept PA-4 CAT-3 power chassis, part number 01044-000, is an upgraded replacement for the Adept PA-4. The PA-4 CAT-3 includes AC-DC power conversion electronics that support a range of Adept power amplifiers and robot control modules. In addition, the PA-4 CAT-3 includes dual (redundant) high-power AC contactors that, in combination with the sMAI (smart Multi-Axis Interface) module, meet the Category-3 E-Stop requirements per EN-954. The PA-4 can be configured with E, F, and G amplifier modules to support the AdeptSix robot systems. (See [Section 1.3 on page 11](#) for more details on amp modules.)

The amplifiers in the AdeptSix robot systems are controlled by an sMAI distributed-control module, part number 03200-000. The sMAI module resides in the PA-4 chassis and contains a RISC microprocessor and interface circuitry that close the servo loops for high-performance robot motion.

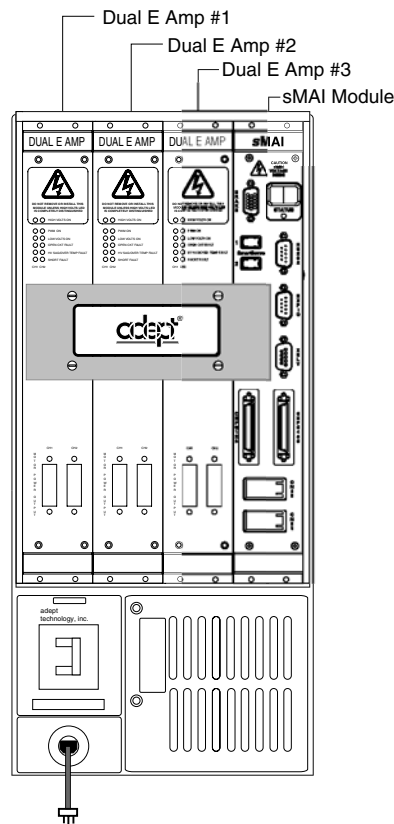

Figure 4-1. Adept PA-4 Power Chassis with sMAI Module

The sMAI, as with all of Adept's distributed-control products, is connected to a host Adept SmartController via the SmartServo interface (based on IEEE 1394).

The PA-4 CAT-3 features:

- AC-DC power conversion for amplifier modules
- Multiple amplifier/module support (4 slots)
- EN-954 Category 3-compliant E-Stop contactors

The sMAI module features:

- RISC microprocessor for servo loop control
- Interfaces to 6 axes of Adept power amplifiers
- Interfaces to robust digital serial absolute encoders
- Interfaces to 6 axes of electromechanical brakes
- Redundant E-Stop and teach mode safety circuits
- Smartservo (IEEE-1394) interface for distributed control

See [page 40](#) for a description of the connectors and indicators on the sMAI.

4.2 E, F, and G Amplifier Modules

The E, F, and G Amplifier modules are “dual” (dual-channel) plug-in modules that contain the circuitry and amplifying components for driving two of the motors in an AdeptSix robot. See [Table 4-1](#).

Table 4-1. AdeptSix Amplifier Functions

	Amp Slot 1 (left)	Amp Slot 2 (center)	Amp Slot 3 (right)
AdeptSix 300 and AdeptSix 300CR	E Amp drives motors 1 and 4	E Amp drives motors 2 and 5	E Amp drives motors 3 and 6
AdeptSix 600	F Amp drives motors 1 and 4	G Amp drives motors 2 and 5	F Amp drives motors 3 and 6

NOTE: Connectors on E, F, and G amps have the same functionality.

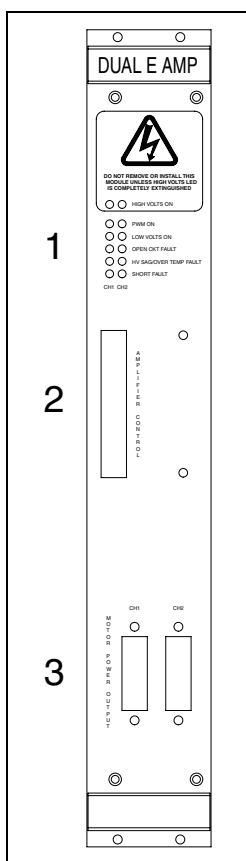

1. **Status LEDs.** The left column of LEDs is for the first motor controlled by this module; the right column is for the second motor controlled by this module. When an LED is on, it indicates the following conditions:

High Volts On indicates high voltage to the amps is turned on.

PWM On indicates that current servo is on. It does not go on until calibration is complete.

Low Volts On indicates the low voltage supply in the power chassis is on.

Note: the three LED pairs below indicate faults and are visible momentarily before the system turns off.

Open Ckt Fault indicates that an open circuit in the motor leads has been detected.

HV Sag/Over Temp Fault left LED, when lit, indicates that the fault was caused by a sag in voltage. The right LED, when lit, indicates the fault was caused by an over-temperature condition on the amplifier heat sink.

Short Fault indicates that an over-current in the motor leads has been detected.

2. **Amplifier Control** connector: the sMAI-to-Amp cable is installed on this connector at the factory. This connector is covered when shipped and users should not need to access it.
3. **Motor Power Outlet** connectors: the Arm Power cables are installed on these connectors.

Figure 4-2. Amplifier Module Connectors and Indicators

4.3 sMAI Module

The Adept sMAI module is a single-slot board designed to control the motion axes on an AdeptSix robot. The sMAI connectors and indicators are described in [Figure 4-3](#).

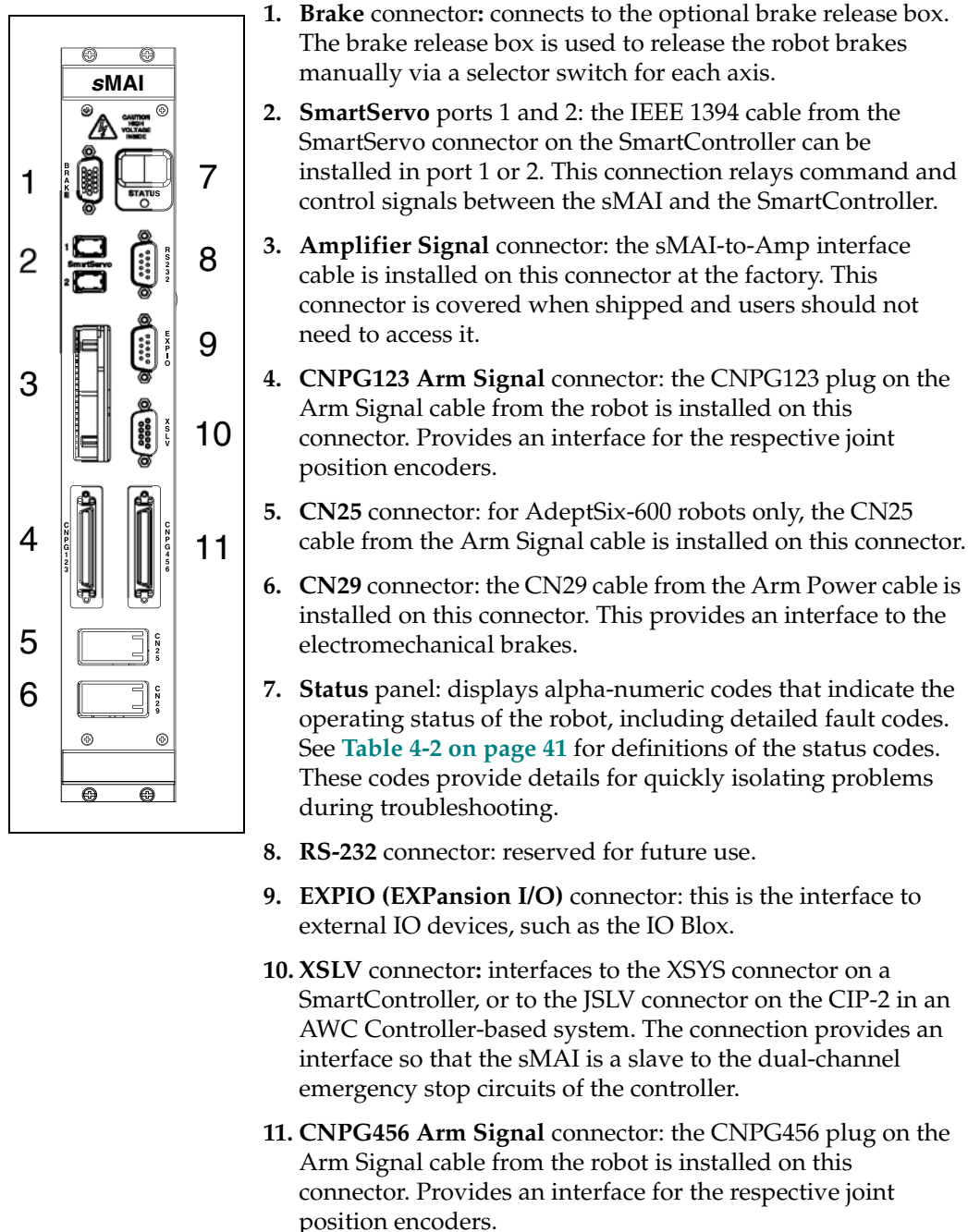

Figure 4-3. sMAI Module Connectors and Indicators

Table 4-2. sMAI Status Panel Codes

LED	Status Code	LED	Status Code
OK	No Fault	h#	High Temp Amp (Joint #)
ON	High Power ON Status	H#	High Temp Encoder (Joint #)
MA	Manual Mode	hV	High Voltage Bus Fault
24	24 V Supply Fault	I#	Initialization Stage (Step #)
A#	Amp Fault (Joint #)	M#	Motor Stalled (Joint #)
B#	IO Blox Fault (Address #)	NV	Non-Volatile Memory
AC	AC Power Fault	P#	Power System Fault (Code #)
D#	Duty Cycle Exceeded (Joint #)	PR	Processor Overloaded
E#	Encoder Fault (Joint #)	RC	RSC Fault
ES	E-Stop	SW	Watchdog Timeout
F#	External Sensor Stop	S#	Safety System Fault (Code #)
FM	Firmware Mismatch	T#	Safety System Fault (Code 10 + #)
FW	IEEE-1394 Fault	V#	Hard Envelope Error (Joint #)

For more information on status codes, go to the Adept Document Library on the Adept Web site, and in the Procedures, FAQs, and Troubleshooting section, look for the *Adept Status Code Summary* document.

Installation for AdeptOne Robots

5

5.1 Overview

The PA-4 includes AC-DC power conversion electronics that support a range of Adept power amplifiers and robot control modules. The PA-4 is configured with A and B+ Amplifier modules to support the AdeptOne robot systems.

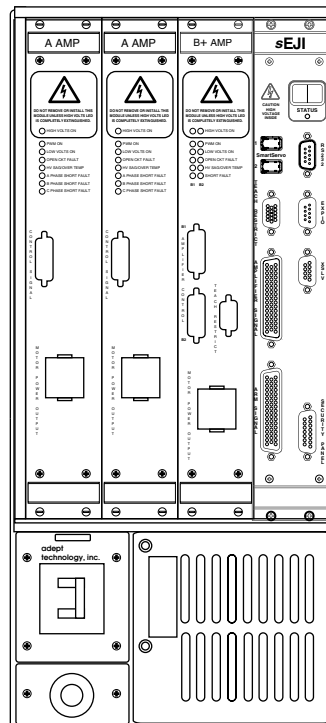

Figure 5-1. PA-4 with sEJI Module

5.2 A Amplifier Modules

The A Amplifier module is a plug-in module that contains the circuitry and amplifying components to drive the Joint-1 or Joint-2 motor in an AdeptOne robot. In a typical robot system, there are two A Amplifier modules in the Adept PA-4 power chassis: A Amp #1 on the far left and A Amp #2 to the right of A Amp #1.

Table 5-1. A Amplifier Functions

	Amp Slot 1	Amp Slot 2	Amp Slot 3
AdeptOne Robot	A Amp #1 drives motor 1	A Amp #2 drives motor 2	B+ Amp drives motors 3 and 4

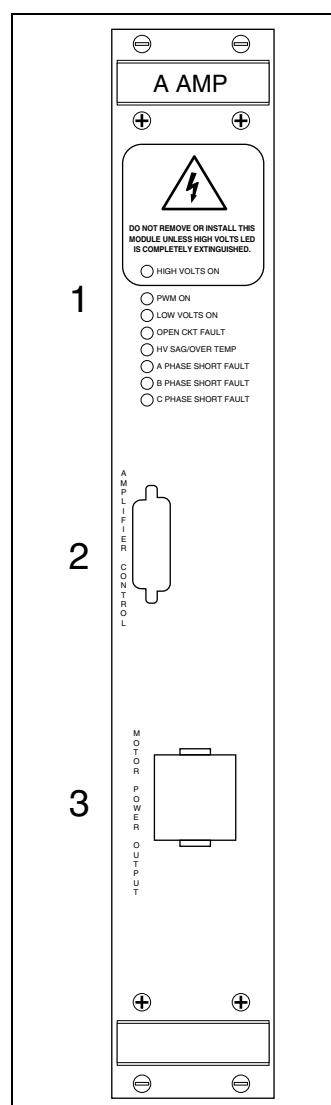

1. **Status LEDs.** When an LED is on, it indicates the following conditions:

High Volts On indicates high voltage to the amps is turned on.

PWM On indicates that current servo is on. It does not go on until calibration is complete.

Low Volts On indicates the low voltage supply in the power chassis is on.

Note: the three LED pairs below indicate faults and are visible momentarily before the system turns off.

Open Ckt Fault indicates that an open circuit in the motor leads has been detected.

HV Sag/Over Temp indicates that the input voltage has dropped below the specified level or an over-temperature fault has been detected on an amp module.

Phase A, B, C Short Fault indicate that an over-current in the motor leads to one of the phases has been detected.

2. **Amplifier Control** connector – the sEJI-to-Amp cable is installed on this connector.
3. **Motor Power Output** connector: the Arm Power cable is installed on this connector.

Figure 5-2. A Amplifier Connectors and Indicators

5.4 sEJI Amplifier Module

The amplifiers in the AdeptOne robot system are controlled by an sEJI (Smart Enhanced Joint Interface) distributed-control module. The sEJI module resides in the PA-4 chassis and contains a RISC microprocessor and interface circuitry that close the servo loops for high-performance robot motion. The sEJI is connected to a host Adept SmartController via the SmartServo interface (based on IEEE 1394).

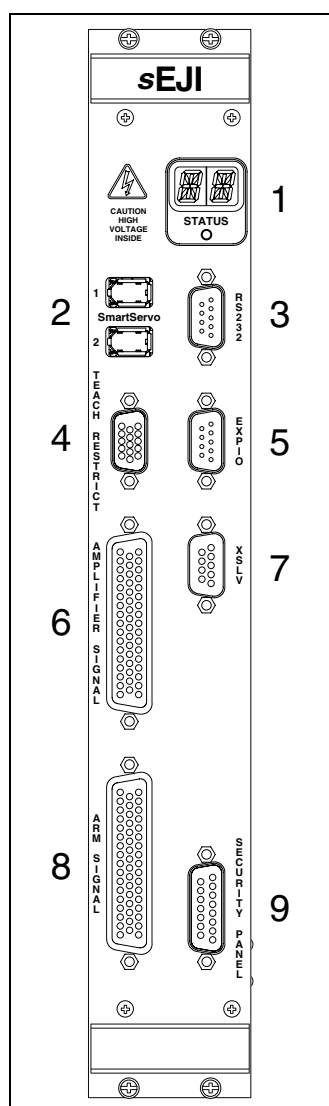

- Status panel:** displays alpha-numeric codes that indicate the operating status of the robot, including detailed fault codes. See [Table 3-2 on page 33](#) for definitions of the status codes. These codes provide details for quickly isolating problems during troubleshooting.
- SmartServo ports 1 and 2:** the IEEE 1394 cable from the SmartServo connector on the SmartController can be installed in port 1 or 2. This connection relays command and control signals between the sEJI and the SmartController.
- RS-232 connector:** reserved for future use.
- Teach Restrict connector:** used for optional CAT-3 safety installations. When used, the Teach Restrict-to-B+ Amp cable is installed on this connector.
- EXPIO (EXPansion I/O) connector:** this is the interface to external IO devices, such as the IO Blox.
- Amplifier Signal connector:** install the large single plug of the sEJI-to-Amp interface cable on this connector to connect the amps to the sEJI servo module.
- XSLV connector:** interfaces to the XSYS connector on a SmartController. The connection provides an interface to connect the E-Stop safety functionality of the amps, PA-4, and sEJI to the Adept SmartController robot safety system. Must be connected to allow all powered robot operations.
- Arm Signal connector:** install the large arm signal cable on this connector to bring the robot encoder signals into the sEJI servo system.
- Security Panel connector:** used for optional CAT-3 safety installations.

Figure 5-4. sEJI Module Connectors and Indicators

6.1 Adept PA-4 Air Filter Inspection and Cleaning

The air filter, located on the front of the chassis, should be *inspected regularly and cleaned* at the first sign of dust or dirt buildup. The filter must be inspected and cleaned at least once per month. Regular cleaning will prolong the life of the filter. If the filter becomes clogged or unusable for any reason, order a new air filter. The PA-4 filter part number is 40330-11200.



WARNING: Dangerous voltages are present inside the power chassis. Turn off the power to the power chassis and protect it against an unauthorized return to service before opening the front grill to inspect the air filter. Failure to observe this warning could cause injury or damage to your equipment.

1. Turn off the power to the power chassis and protect it against an unauthorized return to service.
2. Open the front grill by loosening two screws and swinging the grill out.
3. Pull the air filter out and inspect it for dust or dirt particles. If cleaning is required, use compressed air to clean the filter. (Follow all appropriate safety procedures regarding the use of compressed air.)
4. Replace the cleaned air filter and secure the grill.

6.2 PA-4 Power Chassis Circuit Breaker and Fuse Information

Chassis Circuit Breaker

The power chassis circuit breaker is rated at 15 A, and is located on the lower-left front of the chassis, on the power entry module. It also functions as an on/off switch to isolate the chassis.



CAUTION: If the circuit breaker trips it indicates an internal fault. Do not reset the circuit breaker yourself: Contact Adept Customer Service (see [Section 1.4 on page 13](#)).

Chassis and Amplifier Module Fuses

Six chassis fuses are located inside the base of the power chassis on the power control board. These fuses are not user-replaceable. If you suspect that a chassis fuse has blown, contact Adept Customer Service.

In addition to the fuses in the power chassis, there are additional fuses located inside the power amplifier modules. The amplifier fuses are not user-replaceable. If you suspect that an amplifier fuse has blown, contact Adept Customer Service.



CAUTION: Failure of a chassis or an amplifier fuse indicates an internal circuit fault, which must be corrected before the fuse is replaced. Do not attempt to replace the fuse yourself: Contact Adept Customer Service.

6.3 Removing and Installing Amplifier and Control Modules

NOTE: For a PA-4 chassis used with an Adept Viper or Cobra robot system, see [Section 3.5 on page 35](#) for information on removing the interface box.

The Adept PA-4 power chassis ships from the factory with the amplifier modules installed in the chassis. Any unused slots are filled with blank covers. Normally, you will not need to remove the amplifier modules. If you do need to remove and reinstall a module, follow the instructions below. The four slots in the chassis are not interchangeable: Some slots have special control signals. The amplifier modules are factory-installed in the correct slots. Contact Adept Customer Service if you need to relocate any modules.



WARNING: Do not attempt to install or remove any amplifier modules without first turning off the power to the power chassis and all related external power supplies. Failure to observe this warning could cause injury or damage to your equipment.

Removing Amplifier Modules



CAUTION: Do not expose the amplifier modules to electrostatic discharge (ESD) while you are handling or storing them. Adept recommends using an antistatic ground strap on your wrist when handling modules.

1. Turn off the PA-4 power chassis and the SmartController.
2. Note the location of any cables connected to the module, then disconnect them.
3. Loosen the captive screws at the top and bottom of the module.
4. Using both the top handle and bottom handle, pull the module straight out of the chassis. Remove the module from the chassis and store it in a safe place.

Installing Amplifier Modules

1. Turn off the PA-4 power chassis and the SmartController.
2. If the slot has a blank panel installed, loosen the captive screws at the top and bottom of the panel and remove it.
3. Verify that the intended slot for the module is open to accept the module.
4. Align the module with the card guide slots at the top and bottom of the card cage. Slide the module in slowly. Apply straight-forward pressure to the top and bottom handles until it is firmly seated in the rear power connector and the face of the module is flush with the other modules.
5. Do not use excessive pressure or force to engage the connector. If the board does not properly connect with the rear power connector, remove the module and inspect the connector and guide slots for possible damage or obstructions.
6. Tighten the captive screws at the top and bottom of the module.

NOTE: There is an interlock circuit that prevents enabling power if the amp module screws are not tightened securely. This also applies to any blank panel cover(s).



WARNING: There are dangerous voltages present inside the power chassis. Do not attempt to operate the PA-4 without blank panel cover(s) installed in any unused slots.

6.4 PA-4 CAT-3 Power Chassis LED Functions

The labels on the lower-right corner of the front of the power chassis are for diagnostic LEDs that can be viewed through the front grill. The functions for these LEDs are shown in [Table 6-1](#). These LEDs are typically for Adept Field Service use only.

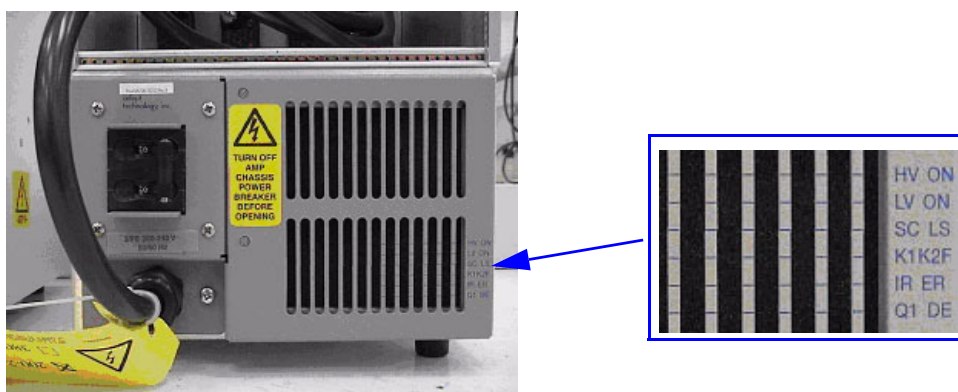

Figure 6-1. PA-4 Chassis LED Locations

Table 6-1. CAT-3 PA-4 Chassis LED Functions

LED #	Color	Label	Function Description
1	Yellow	HV ON	This STATUS LED lights approximately 2.5 seconds after high-power relays are energized.
2	Green	LV ON	This STATUS LED lights when +5 V logic power is present.
3	Red	SC LS	This FAULT LED lights when the lower-right mounting screw in any of the four slots is loose. The fault will reset when the screws are tightened.
4	Red	K1-K2-F	This FAULT LED lights when a failure has occurred during cyclic testing of the dual-channel safety relays. The LED will reset when PA-4 power is turned off and on.
5	Red	IR ER	This FAULT LED lights when an inrush error occurs while enabling power. The error may indicate a fault in an amplifier or control module. The LED will reset when PA-4 power is turned off and on.
6	Red	Q1DE	This FAULT LED lights when an over-current error occurs. The error may be caused by a severe power surge or a fault in an amplifier or control module. The LED will reset when PA-4 power is turned off and on.

6.5 Changing the Power Chassis Voltage Setting

This section covers changing the voltage selection for systems that need a different voltage setting for the PA-4 power chassis.

Changing From 380-415 VAC to 200-240 VAC

Complete the following procedure to change the AC voltage setting from 3-phase 380-415 VAC to 3-phase 200-240 VAC. (Refer to your robot manual for information on connecting AC power to the PA-4 power chassis.)



DANGER: Electrical hazard!

Changing the voltage setting in the power chassis must be done by a trained, authorized person. The power supply can injure or kill a person who does not perform this procedure correctly.

Part 1 – Insulating the Power Chassis Power Cord



DANGER: High AC voltage is coupled through capacitors to the blue wire of the PA-4 power chassis power cord. If you change the voltage setting from 380-415 VAC to 200-240 VAC, you must add additional insulation to the blue wire according to the directions provided below. Failure to do this could result in injury or death.

Refer to [Figure 6-2](#) for this procedure.

1. Make sure the power chassis and controller are turned off. Disconnect the PA-4 chassis from the AC power source. Verify that power remains off during all parts of this procedure.
2. If a 5-wire plug has already been installed, remove the plug.
3. This procedure requires two user-supplied pieces of shrink tubing; one 7 mm (1/4-inch) in diameter, the other 19 mm (3/4-inch).
4. Place the 7 mm (1/4-inch) shrink tubing over the end of the blue wire in the power cord and use a heat gun to apply it.
5. Fold the blue wire back.
6. Place the 19 mm (3/4-inch) shrink tubing over the blue wire and the power cord insulation and use a heat gun to apply it.
7. Install a 4-wire plug (or wire directly to an appropriate service disconnect). Refer to your robot manual for PA-4 power cord specifications.

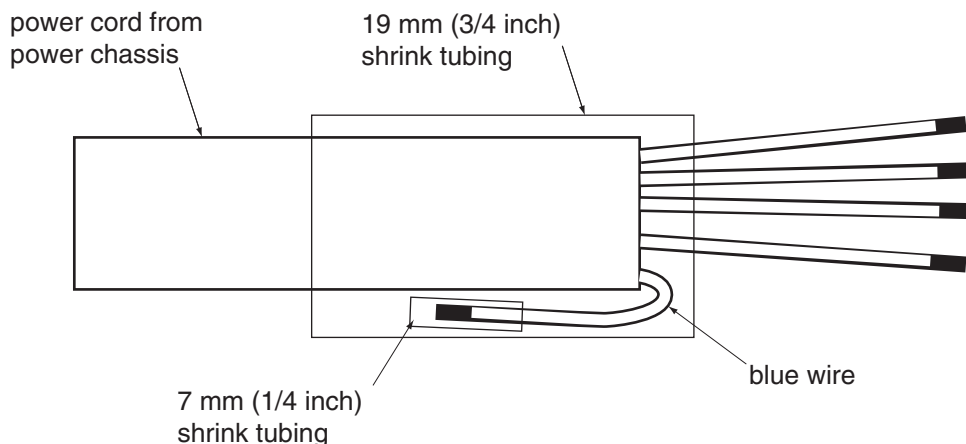

Figure 6-2. Insulating Blue Wire in Power Cord (200-240 VAC)

Part 2 – Rotating the Voltage Selector in the Power Chassis

1. Open the front air-intake grill on the power chassis by loosening two screws and swinging the grill out.
2. Inspect the voltage setting; it is marked on the front of the voltage selector plug. To change the voltage setting, remove the selector, rotate it 180 degrees so the required setting is shown, and re-install it. See [Figure 6-3](#).
3. Close the grill and secure the two screws.
4. Clearly mark or alter the ID label, which is located on the side of the PA-4 chassis, to show the new voltage configuration (see [Figure 1-2 on page 11](#)).

Adept PA-4 Power Chassis with Front Air Intake Grill Removed

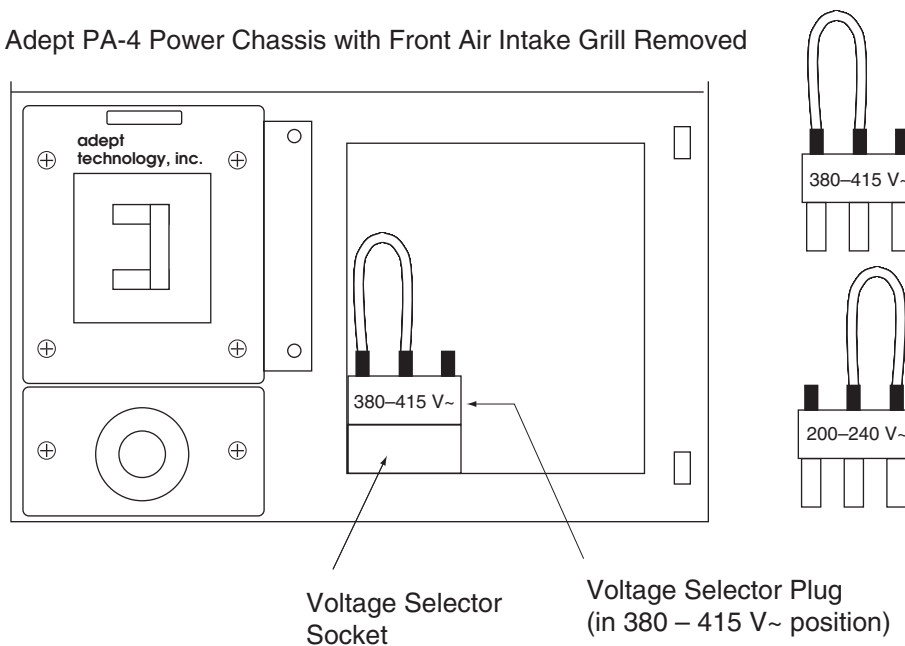

Figure 6-3. Changing Voltage in Power Chassis

Changing From 200-240 VAC to 380-415 VAC

To change the AC voltage setting from 3-phase 200-240VAC to 3-phase 380-415VAC, follow the two-part procedure below.



DANGER: Electrical hazard!

Changing the voltage setting in the power chassis must be done by a trained, authorized person. The power supply can injure or kill a person who does not perform this procedure correctly.

Part 1 – Rotating the Voltage Selector in the Power Chassis

1. Open the front air-intake grill on the power chassis by loosening two screws and swinging the grill out.
2. Inspect the voltage setting; it is marked on the front of the voltage selector plug. To change the voltage setting, remove the selector, rotate it 180 degrees so the required setting is shown, and replace it (see [Figure 6-3 on page 52](#)).
3. Close the grill and secure the two screws.
4. Clearly mark or alter the ID label, which is located on the side of the PA-4 power chassis, to show the new voltage configuration (see [Figure 1-2 on page 11](#)).

Part 2 – Insulating the Power Chassis Power Cord



DANGER: High AC voltage is coupled through capacitors to the blue wire of the PA-4 power chassis power cord. If you change the voltage setting from 200-240 VAC to 380-415 VAC, you must be sure the blue wire is connected properly, according to the directions provided below. Failure to do this could result in injury or death, and damage to the equipment.

1. Make sure the power chassis and controller are turned off. Disconnect the controller and the PA-4 power chassis from the AC power source. Verify that power remains off during all parts of this procedure.
2. If installed, remove the 4-wire plug.
3. Remove and discard the 19 mm (3/4-inch) shrink tubing from the end of the power cord.
4. Remove and discard the 7 mm (1/4-inch) shrink tubing from the end of the blue wire in the power cord (see [Figure 6-2 on page 52](#)).
5. This procedure requires a user-supplied 19 mm (3/4-inch) diameter piece of shrink tubing. Place the shrink tubing over the end of the power cord. Use a heat gun to apply the shrink tubing (see [Figure 6-4 on page 54](#)).
6. Install a 5-wire plug (or wire directly to an appropriate service disconnect). Refer to your robot manual for PA-4 power cord specifications.

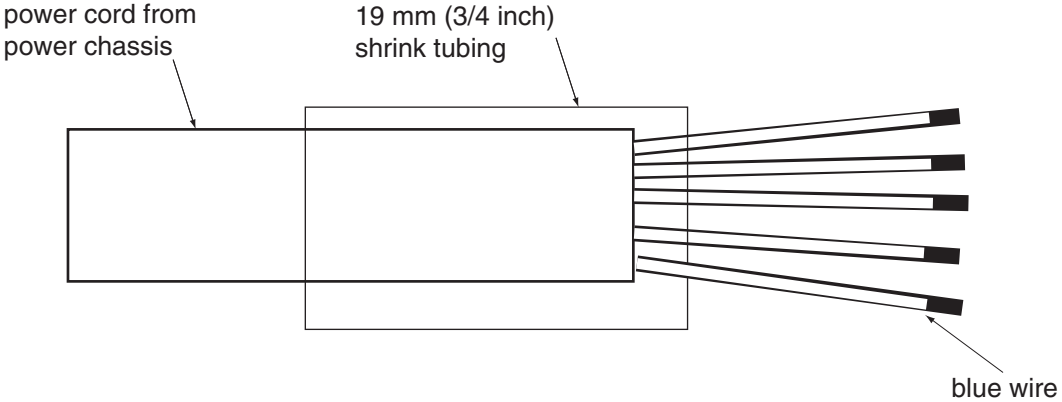

Figure 6-4. Removing Insulation from Blue Wire in Power Cord (380-415 VAC)

- A**
- A amplifier module
 - connections/indications 44
 - functions 44
 - overview 44
- Adept Document Library 14
- Adept Viper robots 25–33
- AdeptOne robots 43–46
- AdeptSix robots 37–41
 - amp assignments 39
- Air filter, cleaning
 - in power chassis 47
- Amplifier module
 - compatibility information 12
 - fuses 48
 - installing 49
 - removing 49
- B**
- B+ amplifier module
 - connections/indications 45
 - functions 45
 - overview 45
- C**
- Changing
 - the power chassis voltage setting 51
 - from 200-240 VAC to 380-415 VAC) 53
 - from 380-415 VAC to 200-240 VAC) 51
- Chassis and amplifier module fuses 48
- Circuit breaker
 - on power chassis 48
- Connectors and indicators
 - on A Amps 44
 - on B+ Amps 45
 - on E, F, and G amps 39
 - on H, I, J, K, and L amps 31
 - on sDAI 32
 - on sEJI 46
 - on sMAI 40
- Customer Service assistance 13
- D**
- Dimensions
 - PA-4 mounting brackets 23
- PA-4 power chassis 23
- Document Library CD-ROM 13, 14
- E**
- E amplifier modules
 - connections/indicators 39
 - functions in AdeptSix robots 39
- EN 60204 15
- Environmental requirements 10
- External brake connector
 - mating connector 35
 - pinouts 34
 - wire list 34
- F**
- F amplifier modules
 - connections/indicators 39
 - functions in AdeptSix robots 39
- Fuses
 - amplifier chassis 48
 - amplifier module 48
- G**
- G amplifier modules
 - connections/indicators 39
 - functions in AdeptSix robots 39
- H**
- H amplifier module
 - connections/indicators 31
 - functions 30
 - overview 30
- How Can I Get Help? 13
- I**
- I amplifier module
 - connections/indicators 31
 - functions 30
 - overview 30
- Installation
 - PA-4 in a rack or panel mount 20
- Installing
 - amplifier modules 49
 - mounting brackets on PA-4 21
- Insulating blue wire in power cord
 - 200-240 VAC 52

- 380-415 VAC 54
- Interface box
 - location on PA-4 26, 27
 - removing 35
- J**
- J amplifier module
 - connections/indicators 31
 - functions 30
 - overview 30
- K**
- K amplifier module
 - connections/indicators 31
 - functions 30
 - overview 30
- L**
- L amplifier module
 - connections/indicators 31
 - functions 30
 - overview 30
- LEDs, status
 - A amps 44
 - B+ amps 45
 - E Amps 39
 - F Amps 39
 - G Amps 39
 - H amps 31
 - I amps 31
 - J amps 31
 - K amps 31
 - L amps 31
 - power chassis 50
 - sEJI 46
- M**
- MAI-2 module
 - compatibility information 12
- Maintenance
 - cleaning power chassis air filter 47
- Manuals, related 13
- Mounting brackets
 - dimensions 24
 - install positions for PA-4 21
 - installation 20
- Mounting, PA-4 chassis 19
- O**
- Operating environment specifications, for power chassis 10
- Overview of PA-4 power chassis 25, 37, 43
- P**
- PA-4 CAT-3
 - compatibility information for plug-in modules 12
 - identification methods 11
 - LED functions 50
 - product ID label 11
- PA-4 power chassis
 - air filter inspection and cleaning 47
 - changing voltage setting (From 200-240 VAC to 380-415 VAC) 53
 - changing voltage setting (From 380-415 VAC to 200-240 VAC) 51
 - circuit breaker 48
 - dimensions 23
 - external brake connector 34
 - fuses 48
 - interface box 35
 - interlock circuit 49
 - overview 25, 37, 43
 - panel mounting 20
 - rack mounting 20
- Panel mounting, PA-4 20
- Panel, status
 - for amps 46
- Plug-in modules
 - amp and control modules compatibility information 12
- Product ID label for PA-4 CAT-3 11
- R**
- Rack mounting the PA-4 20
- Related manuals 13
- Removing
 - and installing amplifier modules 48
- Requirements
 - environmental 10
 - facility 10
- Robot system safety 15
- Robot, amp to motor assignments
 - A amp 44
 - B+ amp 44
 - E amp 39
 - F amp 39
 - G amp 39
 - H amp 30
 - I amp 30
 - J amp 30
 - K amp 30
 - L amp 30
- Robotic Industries Association (RIA) 15
- S**
- Safety 14

- sources for information 16
- sDAI module
 - connections/indicators 32
 - overview 29
- sDAI module, status panel codes 33, 41
- sEJI module
 - connections/indicators 46
 - functions 46
 - overview 46
- sMAI module
 - compatibility information 12
 - connections/indicators 40
 - overview 38
- Sources for international standards and directives 16
- Space around the chassis 19
- Status LEDs
 - A amps 44
 - B+ amps 45
 - E amps 39
 - F amps 39
 - G amps 39
 - H amps 31
 - I amps 31
 - J amps 31
 - K amps 31
 - L amps 31
 - power chassis 50
 - sEJI 46
- Status panel codes, on
 - sDAI module 33
 - sMAI module 41
- Status panel, location on
 - sDAI module 32, 46
 - sEJI module 46
 - sMAI module 40
- Support 13

V

- Voltage
 - changing setting on power chassis 51, 53

P/N: 02725-000, Rev F

adept[®]
3011 Triad Drive
Livermore, CA 94551
925•245•3400